

 bralco

lux

 **CONCEPTYS**  
AMÉNAGEMENT DE BUREAUX

# lux 01

Location:

**Paris**

48° 51' 12 N  
2° 20' 55 E

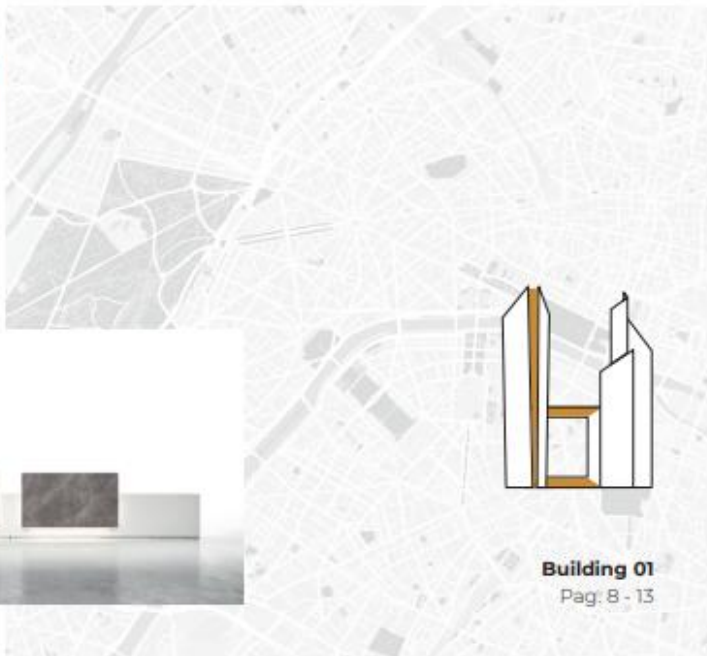

**Building 01**  
Pag. 8 - 13

# lux 02

Location:

**New York**

40° 42' 51 N  
-74° 0' 21 O



**Building 02**  
Pag. 14 - 19

# lux 03

Location:

**London**

51° 30' 30 N  
-0° 7' 32 O



**Building 03**  
Pag. 20 - 25

# lux 04

Location:

**Milan**

45°28'38"28 N  
09°10'53"40 E



**Building 04**  
Pag. 26 - 31

# lux: light and refined



**intensità luce regolabile**, adjustable light intensity, intensité lumineuse réglable, einstellbare Lichtstärke, dimbare Lichtstärke, intensidad de luz regulable

1



**numerosa finiture**, numerous fine finishes, nombreuses finitions, zahlreiche Oberflächen, verschillende afwerkingen, numerosos acabados

2



**mensole su posizioni personalizzate**, custom location of the front module risers, étagères avec positions personnalisables, individuell einsetzbare Aufsätze, aanpasbare frontmodule, repisas con posiciones que se pueden personalizar

3



**mensola per oratore**, lectern module riser, étagère pour orateur, rednerpult, leenzer module, repisa para orador

4



**passaggio cavi ed elettrificazione integrati**, channels for cables & wires, integrated electrifying equipment, passage de câbles et électrification intégrés, integrierte Kabelführung und Elektrifizierung, openingen voor bekabeling en inbouw dataunits, pasacables y electrificación integrable

5



**piano elevabile**, height adjustable desk top, plateau réglable en hauteur, höhenverstellbare Platte, hoogverstelbaar bureaublad, tapa que se puede elevar

6



**finiture, finishes, finitions, Oberflächen, acabados**

**mensole, shelves, étagères, konsolen, ménsulas**

**melaminico, melamina, mélamina, melamin, melamina**



**vetroceramica, glass ceramic, vitroceramique, gläseramik, vidrio cerámica**



**legno, veneer, bois, holz, madera**



**elettrificazione, electrification, électrification, elektrifizierung, electrificación**

**parti metaliche, metal structure, structure métallique, metalstruktur, estructura metálica**



**zoccolo, plinth, socle, Sockel, zócalo**

**chromo lucido, glossy chrome, chromé brillant, Chrom poliert, cromo brillo**

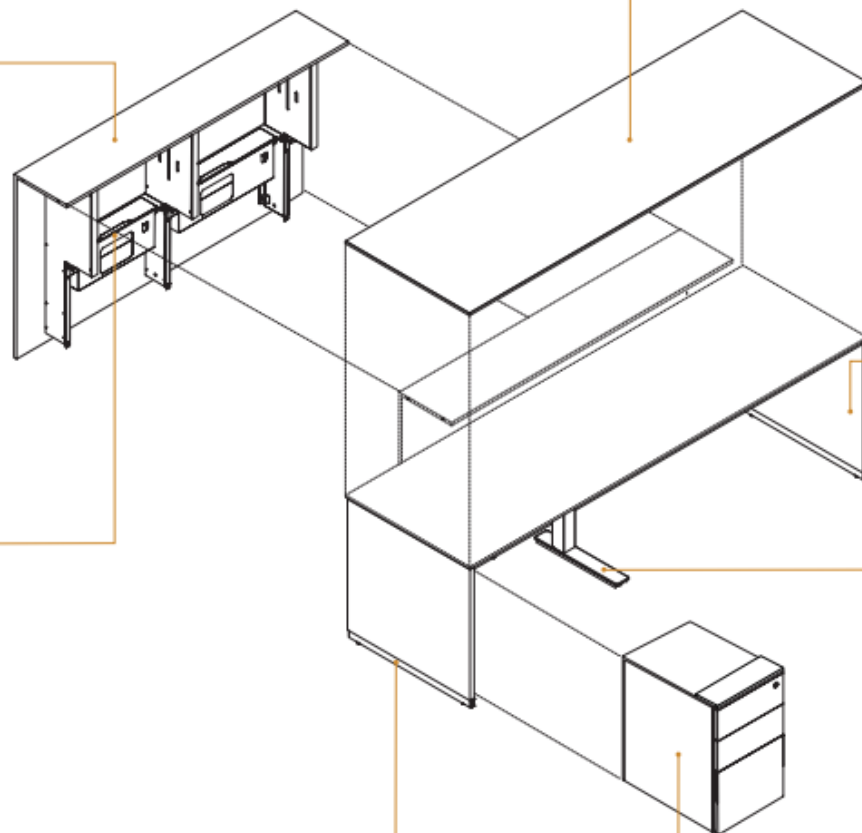

**piano, top, plateau, platte, plano**

**melaminico, melamina, mélamina, melamin, melamina**



**bancone, reception desk, réception, Rezeption, recepción**

**melaminico, melamina, mélamina, melamin, melamina**



**gambe, legs, piètements, Beine, patas**

**metallo, metal, métal, metal, metal**



**cassettiera, pedestals, caissons, container, cajonera**

**melaminico, melamina, mélamina, melamin, melamina**



# lux 01

La luce calda che avvolge e sospende l'elemento mensola,  
forma pura che illuminata caratterizza la reception.

The warm light which embraces, then floats the front module riser,  
pure form that enlightens the reception desk.

La lumière chaude qui entoure et suspend l'élément tablette,  
forme pure qui illumine et caractérise la banque d'accueil.

Das warme Licht, das das Regalelement umgibt und schweben  
lässt, eine reine Form, deren Leuchtkraft das Thekenbild prägt.

Via de verticale staander wordt de receptie fraai en warm uitgelicht.

La luz cálida que envuelve y suspende el elemento de la repisa,  
forma pura que iluminada caracteriza la recepción.







Alle numerose finiture tradizionali  
si aggiungono nuovi materiali  
come il vetroceramica o il Fenix®.

To the numerous traditional finishes  
are added new materials  
such as ceramic-glass or Fenix®.

Aux nombreuses finitions traditionnelles  
s'ajoutent de nouveaux matériaux  
tels que la vitrocéramique ou le Fenix®.

Zu den zahlreichen traditionellen Oberflächen  
kommen neue Materialien  
wie Glaskeramik oder Fenix hinzu®.

Aan de reeds uitgebreide serie  
afwerkingen zijn nieuwe materialen  
toegevoegd zoals keramisch glas of Fenix®.

A los acabados tradicionales se suman  
los nuevos materiales como  
el vitrocerámico o el Fenix®.



## lux 02

Varietà di configurazioni ottenute dall'alternanza mensole e bancone per soluzioni angolari destre o sinistre.

Variety of configurations obtained by the interchange between the front module risers and the counter module for right or left corner solutions.

Variété de configurations obtenue avec l'alternance d'étagères et de comptoirs pour des solutions angulaires droites ou gauches.

Vielfältige Konfigurationen, die sich im Wechselspiel zwischen Aufsätzen und Thekenmodulen zu rechten oder linken Winkelösungen zusammensetzen lassen.

Door uitwisseling van de frontmodulen en de linker- of rechter balie-modulen kunnen er verschillende opstellingen worden gerealiseerd.

Variedad de configuraciones que se obtienen alternando repisas y mostrador para soluciones angulares derechas o izquierdas.







**Tra gli accessori è possibile inserire all'interno della mensola il cassetto metallico porta fogli.**

Among the accessories will fit in a 3 shelves epoxy painted metal box for A4 letter sheets.

Parmi les accessoires, il est possible d'insérer un tiroir métallique support feuilles à l'intérieur de l'étagère.

Als Zubehör lässt sich im Aufsatz eine praktische Blattablaße unterbringen.

Onder de balieopzet past een epoxy metalen 3-laden ladenkast voor opberging van A4 papier.

Entre los accesorios se puede introducir, dentro de la repisa, el cajon metalico para hojas.

Il prodotto Lux configurabile come bancone per sala conferenze, con mensola dedicata all'oratore e sagomatura speciale del piano.

The LUX counter for conference environments, with lectern module and a custom shaped top.

Le produit Lux peut être configuré comme un pupitre pour salle de conférence, avec une étagère dédiée à l'orateur et une forme spéciale du plateau.

Die Kollektion LUX kann als Tisch für Konferenzsäle konfiguriert werden, mit einem Stehpult für den Redner und einer speziellen Freiformplatte.

De Lux opstelling is geschikt voor congres opstellingen met lessenaarmodule inclusief op maat gemaakte top.

El producto Lux se puede configurar como mostrador para sala de conferencias, con repisa dedicada al orador y perfilado especial de la tapa.

## lux 03







**Sotto la mensola una vaschetta con molteplici funzioni: contiene l'elettrificazione e i pulsanti per l'accensione e la regolazione dell'intensità luminosa.**

Under the front module riser, a multi-functional tray which contains: on and off switches, adjustable light intensity button, electrifying equipment.

Sous l'étagère est positionné un bac avec plusieurs fonctions : il contient l'électrification et les boutons pour allumer et régler l'intensité de la lumière.

Unter dem Aufsatz ein Einbaufach mit vielseitigen Funktionen: darin enthalten sind Elektrifizierung und Tasten zum Einschalten und Einstellen der Lichtstärke.

Onder de frontmodule- uitbreidingsmodule zit een multifunctionele lade met aan/uit schakelaars, dimbare lichtschakelaar en stroomaansluitingen.

Debajo de la repisa una bandeja con muchas funciones: contener la electrificación y los pulsadores para el cebado y el ajuste de intensidad de la luz.



La massima espressione di eleganza nella mensola frontale continua, personalizzabile con finiture di pregio come il Fenix ed il vetroceramica.

The maximum expression of elegance in the one-line front module riser, customizable with fine finishes such as Fenix® and the ceramic-glass.

L'expression maximale de l'élégance dans l'étagère continue, personnalisable avec des finitions de valeur telles que le Fenix et la vitrocéramique.

Der feinste Ausdruck von Eleganz ist in der durchgehenden vorderen Thekenfront, die mit edlen Oberflächen wie Fenix oder Glaskeramik individuell gestaltet werden kann.

Maximale uitstraling kan worden bereikt met de uitbreidings-frontmodule welke in keramisch glas of Fenix® kan worden geleverd.

La maxima expresion de elegancia esta en la repisa frontal continua, personalizable con acabados de valor como Fenix y vitroceramico.

## lux 04







**La cassettiera portante agganciata alla struttura è disponibile nella versione a 3 o 4 cassetti e posizionata lateralmente secondo le esigenze dell'utente. Obbligatoria in caso di alzate in vetroceramica.**

The supporting pedestal fit to the counter structure is available with 3 or 4 drawers and can be locate right or left according to the user's need. Compulsory when ceramic-glass front module risers are in use.

Le caisson porteur fixé à la structure est disponible dans la version à 3 ou à 4 tiroirs. Il est positionné latéralement en fonction des exigences des utilisateurs. Il est obligatoire en cas de étagère en vitrocéramique.

Die an der Struktur verankerte Stützcontainer ist in der Version mit 3 oder 4 Schubladen erhältlich und wird je nach den Bedürfnissen der Benutzer seitlich positioniert. Pflicht bei Glaskeramik-Aufsätzen.

De ondersteunende ladenkast, welke onder de balieopzet past, is verkrijgbaar met 3 of 4 laden en kan naar keuze links of rechts worden geplaatst. Deze is verplicht bij frontmodulen in keramisch glas.

La cajonera de sustentacion, sujeta a la estructura, esta disponible en las versiones de 3 o 4 cajones y colocada en posicion lateral segun los pedidos del usuario. Es obligatoria cuando la repisa es en material vitroceramico.

**bancone, counter, comptoir, Stheke, baile, contador**



w 160-180-200 cm  
w 62"-70 3/4"-78 3/4"

**bancone completo (piano-frontale/gamba, gamba laterale),** complete counter (top-front/leg, comptoir complet, Stheke/Fronten/partermetal, complete baile (werkblad/Fronten/partermet), contador completo (piano-frontale/roostablae)

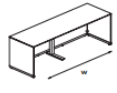

w 220-240-260-280 cm  
w 86 3/4"-94 1/2"-102 1/4"-110 1/4"

**bancone completo (piano-frontale/gamba, gamba laterale),** complete counter (top-front/leg/partermetal leg), comptoir complet (piano-front/partermet/partermet da metal), Fertige Stheke (Fertige-Fronten/partermet/Baile), complete baile (werkblad/Fronten/partermet/partermet), contador completo (piano-frontale/contador para metalico)

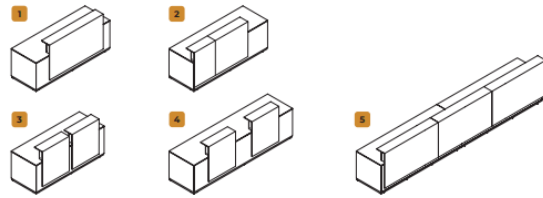

**esempi di componibilità con mensola, modularly example withshelves, examples modularly avec étagères, Beispiele der Anbaumöglichkeiten mit Regalen, voorbeelden voor aanbouwen met planken, ejemplos composición con estanterías**

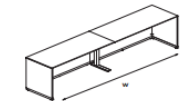

w 320-360-400 cm  
w 126 3/4"-141 3/4"-156 3/4"

**bancone completo (2 piani + 2 frontali/gamba, gamba laterale),** complete counter (2 planes/2 facades/partermet/partermet da metal), Fertige Stheke (2-Facade/2-Fronten/Baile/metal Baile), complete baile (2 werkblad/2Fronten/partermet/partermet), contador completo (2 piano-frontale/roostablae para metalico)

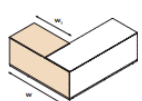

w 180-200-220 cm  
w 70 3/4"-78 3/4"-86 3/4" w 106-126-146 cm  
w 41 3/4"-49 3/4"-57 1/2"

**frontale a piano laterale, front and lateral top, facade et plan lateral, fronten und seitliche, gante frontale en zijdelingse werkblad, frontaley plano laterale**

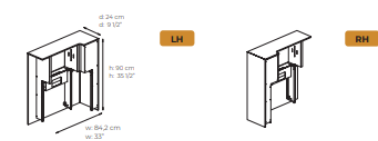

**mensola ad angolo, corner shelf, etagère d'angle, eckiges Regal, hoekstaaf repisa, para ángulo**

**mensole, wall shelves, étagères murale, wandregale, planken, estante de pared**

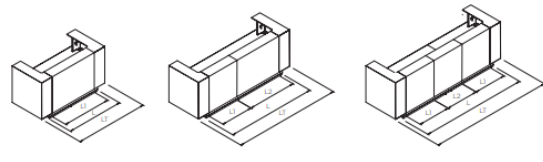
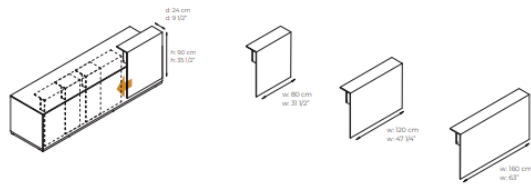

| LT         | L       | LI      |
|------------|---------|---------|
| cm 160     | 180     | 200     |
| in 70 3/4" | 67"     | 47 3/4" |
| cm 220     | 250     | 360     |
| in 86 3/4" | 78 3/4" | 63"     |

| LT          | L        | LI      | L2      |
|-------------|----------|---------|---------|
| cm 280      | 240      | 80      | 120     |
| in 110 1/4" | 94 1/2"  | 31 1/2" | 47 3/4" |
| cm 420      | 400      | 130     | 130     |
| in 165 3/4" | 157 1/2" | 47 3/4" | 47 3/4" |

| LT          | L        | LI      | L2      |
|-------------|----------|---------|---------|
| cm 380      | 360      | 80      | 160     |
| in 149 3/4" | 141 3/4" | 31 1/2" | 63"     |
| cm 420      | 400      | 130     | 130     |
| in 165 3/4" | 157 1/2" | 47 3/4" | 47 3/4" |

**esempi di componibilità con mensola ad angolo, modularly example with corner shelf, examples bewaarden**

**melaminico • melamine • mélamine • melamin • melamina**

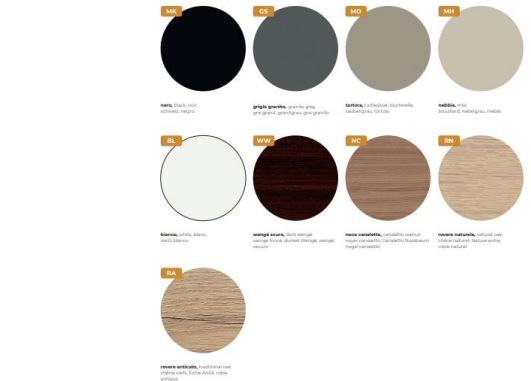

**legno • veneer • bois •holz • madera**



**vetroceramica • glass ceramic • vitroceramique • glaskeramik • vidrio cerámica**

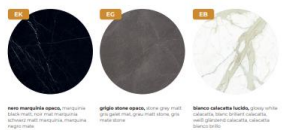

**piano conversazione, conversation top, plan conversation, Platte für Gesprächstisch, zijdelings conferentiebladen, plano de conversación**

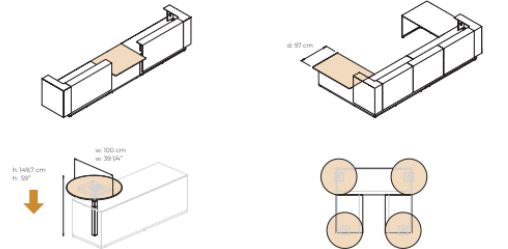

**piano conversazione con colonna elettrica, conversation top with height adjustable column, plan conversation table avec colonne électrique, platte für Gesprächstisch mit elektrische Säule, conferentiebladen met elektrische kolom, plano de conversación con columna eléctrica**

**posizione, position, position, positionierung, posada, posición**

**accessori, accessories, accessoires, zubehör, toebehoren, accesorios**



**caselliera portante con 3/4 cassetti, support portatif with 3/4 drawers, casierio portante avec 3/4 tiroirs, tragender Schubladenkasten mit 3/4 Schubladen, dragend kabinet met 3/4 laden, cajones que llevan con 3/4 cajones**

**caselliera portafogli, shelf tray drawer, tiroir porte documents, Schubladen Blattfächer, bode voor s'waak, cagin para hojas**

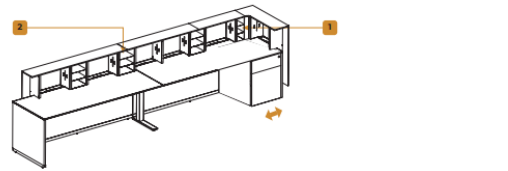

**elettrificazione, electrification, electrification, elektrifizierung, elektrificatie, electrificación**

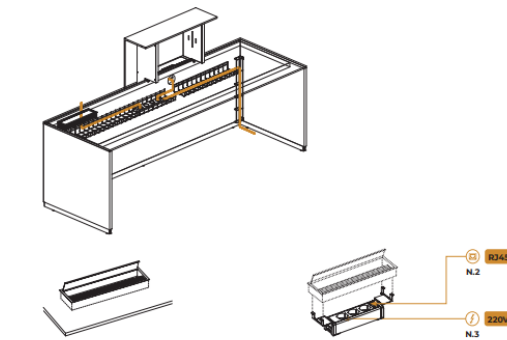

**top access, top access, accès supérieur, top Zugang, top toegang, acceso superior**

**EU - FR - UK**  
**3/4 blocco portapase con staffe e 1 cavo di alimentazione L2000m, 3/4 blocky socket holder with brackets and 1 power cord W.2000m, 3/4 bloc porte prise avec supports et 1 cordon d'alimentation L.2000m, 3/4 blocky socketblock mit brackets und 1 Stromkabel B.2000m, 3/4 de bloques para enchufe con soportes y 1 cable de alimentación A.2000m**



**cestello portacavi, wire cable tray, chemin de câbles, kabelbunchhous, kabelgoot, cestos portacables**



**cestello portacavi, wire cable tray, chemin de câbles, kabelbunchhous, kabelgoot, cestos portacables**



**passacavi verticale, vertical cable carrier duct, chemin de câbles vertical, kabelbunchhous vertikal, kabelbongangdops, pasacables vertical**



**passacavi verticale, vertical cable carrier duct, chemin de câbles vertical, kabelbunchhous vertikal, kabelbongangdops, pasacables vertical**